

PERISTALTIC PUMP PP 600

Manual and User Guide

Please read this manual before operating this product



PSI, spol. s r. o., Drásov 470, 664 24 Drásov, Czech Republic
FAX: +420 511 440 901, TEL: +420 511 440 011, www.psi.cz

© PSI (Photon Systems Instruments), spol. s r. o. (hereinafter PSI), 2019

This document and its parts can be copied or provided to a third party only with the express permission of PSI.

The contents of this manual have been verified to correspond to the specifications of the device. However, deviations cannot be ruled out. Therefore, a complete correspondence between the manual and the real device cannot be guaranteed. The information in this manual is regularly checked, and corrections may be made in subsequent versions.

The visualizations shown in this manual are only illustrative.

This manual is an integral part of the purchase and delivery of equipment and its accessories and both Parties must abide by it.

TABLE OF CONTENTS

TABLE OF CONTENTS	3
1. TECHNICAL SPECIFICATIONS	4
2. GENERAL INFORMATION	5
3. COMPONENTS OF THE PERISTALTIC PUMP	6
4. DESCRIPTION OF THE PERISTALTIC PUMP	7
5. CARE AND MAINTENANCE	8
6. INSTALLATION	9
7. OPERATION INSTRUCTIONS	11
8. COMMAND EXPLANATION	12
9. WARRANTY TERMS AND CONDITIONS	14
10. LIST OF PICTURES	15

1. TECHNICAL SPECIFICATIONS

Number of Rollers:

4

Number of Channels:

1

Rotor Rotation:

Clockwise or counterclockwise

Tubing:

Norprene A-60-F tubing 6-4 mm

Flow-Rate Range:

0.2 ml/min – 50 ml/min

Speed Accuracy:

±0, 5 %

Control:

Manual via pump display; digital (trigger signal); computer (USB, I2C)

USB Interface:

Operation controlling via PC; up to 8 pump cascading

Operating Panel:

4-button membrane keypad

Power:

12V DC (110/220 VAC adapter), > 30 W

Dimension:

250 x 213 x 120 mm

Weight:

2.4 kg

Work environment:

5 – 40 °C

2. GENERAL INFORMATION

Peristaltic Pump PP 600 is used for accurate and homogenous pumping of variety of fluids. PP 600 is compact, lightweight device that can conveniently fit into most experimental setups. PP 600 has simple set-up design with minimum key-presses for intuitive operation.

Pump flow-rate runs between 0.2 and 50 ml/min. The speed of rotation and thus of pumping can be controlled manually via the pump display, digitally via a trigger signal, or by a PC via USB interface.

The fluid delivery occurs with minimum shear so the potential damage to the biological material is minimal.

The Peristaltic Pump PP 600 is equipped with four channels for liquid delivery and one gas valve that can be used for regulation of CO₂ inflow into the culture (this feature can be used for pH-stat or chemostat cultivation, for more information see – Photobioreactor FMT 150 manual; chapter Peristaltic Pump Installation). It is designed to be used with the parent device only (for example Photobioreactor FMT 150). Up to three additional valves may be enabled for operation as an option (Fig. 1).



Fig. 1 Model PP 600.

3. COMPONENTS OF THE PERISTALTIC PUMP

Carefully unpack the carton. You should have received the following items, as described and shown below.

1. **Peristaltic pump PP 600.**
2. **Power unit 12V DC (110/220 VAC adapter) with power cable.**
3. **Communication cable.**
4. **USB cable.**
5. **Plastic Norprene A-60-F tubing* and connectors - 4+4 Luer Locks (female and male) and 5 pieces of Norprene tubing (silicone tubing not included).**
6. **This operation manual (printed version).**
7. **Optional Accessories (according to your specific order).**

Note: If any item is missing, please, contact the manufacturer. Please check the carton for any visible external damage. If you find any damage, notify the carrier and PSI immediately. The carton and all packing materials should be retained for inspection by the carrier or insurer. For customer support, please write to:

support@psi.cz



Fig. 2 Components of Peristaltic Pump.

* Norprene tubing offers good mechanical properties under a wide range of operating temperatures. Highly durable, Norprene tubing is resistant to fatigue, ozone, ultraviolet, acids, alkalies, water, and most oils and lubricants.

4. DESCRIPTION OF THE PERISTALTIC PUMP

Pump flow-rate of the peristaltic pump runs between 0.2 and 50 ml/min. The speed of rotation and thus of pumping can be controlled manually via the front display. 4 button keypad is used to operate the system. Rotor rotation is clockwise or counterclockwise. Peristaltic pump rotor has four rollers.

FRONT PANEL:

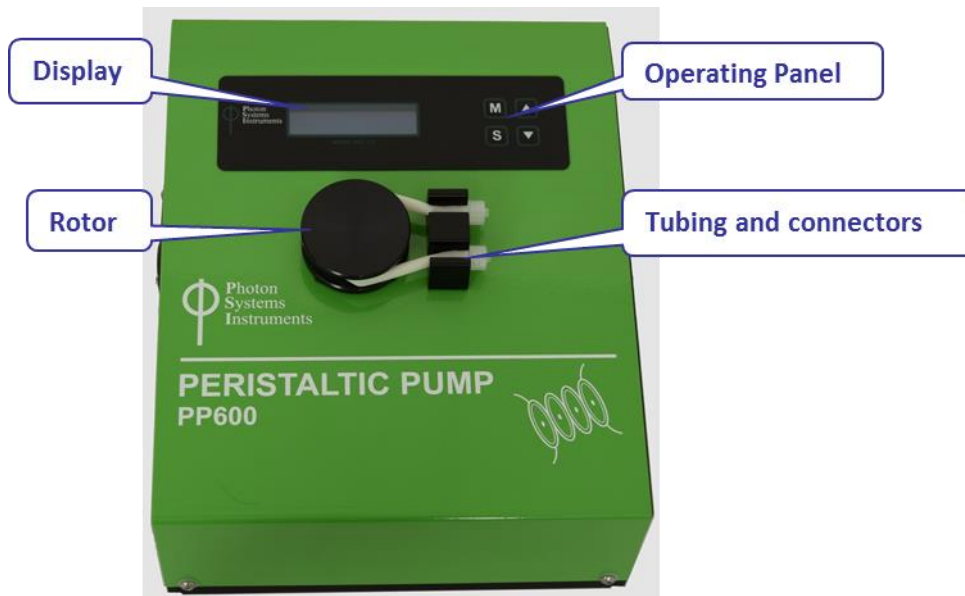

Fig. 3 Front panel.

REAR PANEL:

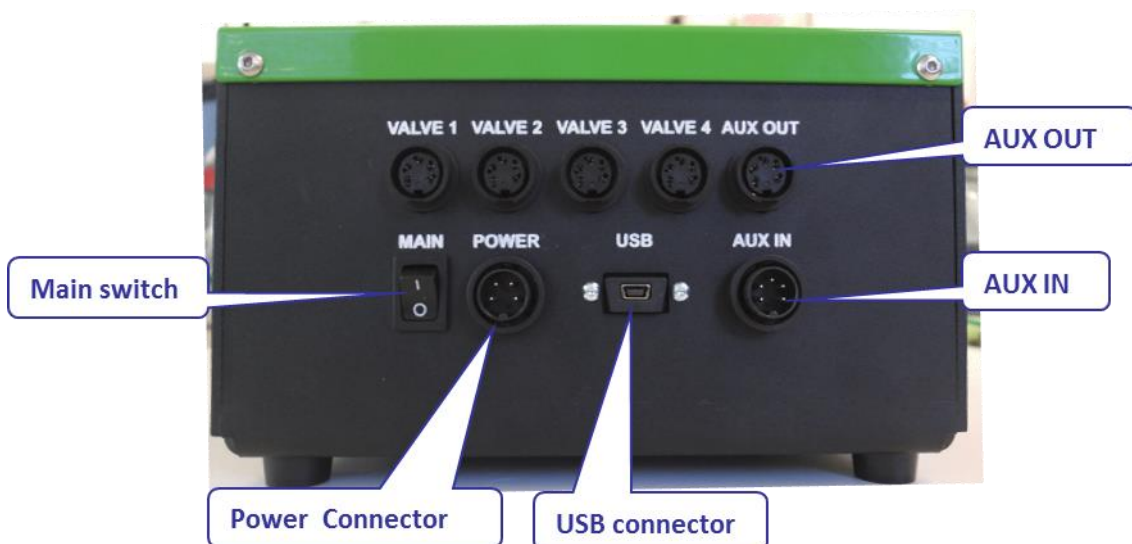

Fig. 4 Rear panel.

5. CARE AND MAINTENANCE

- Loosen the tubing when pump is not used. The tubing can get deformed and subsequently lose elasticity if compressed for a prolonged period.
- Keep the tubing and rotor clean. If any solvent (including water) spills on any part of the device, clean the solvent. Certain solvents, such as strong detergents and acids, can permanently damage the pump.
- Change tubing immediately if it is visibly worn and the elasticity is reduced.
- Use only compatible tubing that came with the unit or substitute tubing of the same size. (Norprene tubing 6-4mm, silicone tubing 6-4 mm)
- There are no user-serviceable parts inside the pump. Unauthorized modification or repair will void the warranty.

Note: Norprene tubing has very good mechanical properties. After a month of continuous use, the volume of pumped fluid differs by an average of 0.9 %.

6. INSTALLATION

Peristaltic Pump PP 600 can be used as stand-alone device or can be connected to other devices that will automatically based on pre-defined protocol control the operation of the Peristaltic Pump. Here we show how to perform initial set-up of the PP as separate device. For Information how to connect the pump to the Photobioreactor FMT 150 please read Photobioreactor manual, chapter Peristaltic Pump Installation.

Follow the instructions below to install and operate the peristaltic pump:

- First assemble and connect the Peristaltic pump with power. Connect the Norprene plastic tubing with the provided Luer Lock connectors (male). Ensure that the end of the tubing is pushed all the way to the end of the Luer Lock fitting. If the connection with Luer Locks is not tight, small air leak may occur during operation of the PP resulting in the pump not working properly.
- Insert one end of the tube in the holder and wind the tube as shown in the figure below around the rotor (Fig. 5 A, B, C). Place the second end of the tube into the holder (Fig. 5 C). Ensure that the end of the tubing is pushed all the way to the end of the Luer Lock fitting. If this is not done small air leak may occur resulting in the pump not working properly.
- Attach provided female Luer Lock connector to the silicone tube and connect it to the peristaltic pump as shown in Fig. 5 D, E. Again, ensuring that the tubing is pushed all the way to the end of the Luer Lock connector.
- Now connect one end of the silicone tube to the bottle with the desired fluid (make sure it is tightly sealed bottle otherwise you can experience problems with the suction fluid).
- The other end of silicone tubing place into the waste container (volume of liquid in the bottle with the desired fluid should match the volume of waste container to avoid overflow and cause possible damage to the pump).
- Now is Peristaltic pump assembled for its first use and for example calibration of flow or first test of Peristaltic Pump (Fig. 6).
- Connect the Peristaltic Pump via the power supply cord into the "POWER" connector of the Peristaltic Pump (Fig. 7).
- Now set the rotor rotation so that was sucked desired fluid and drain direction into a waste container
Setting → Rotate [RIGHT/LEFT]: Use this command to change the direction of rotor rotation. Use "S" key to set right or left rotor rotation.
- Now set the flow rate and other parameters according Operation Instruction (next chapter)

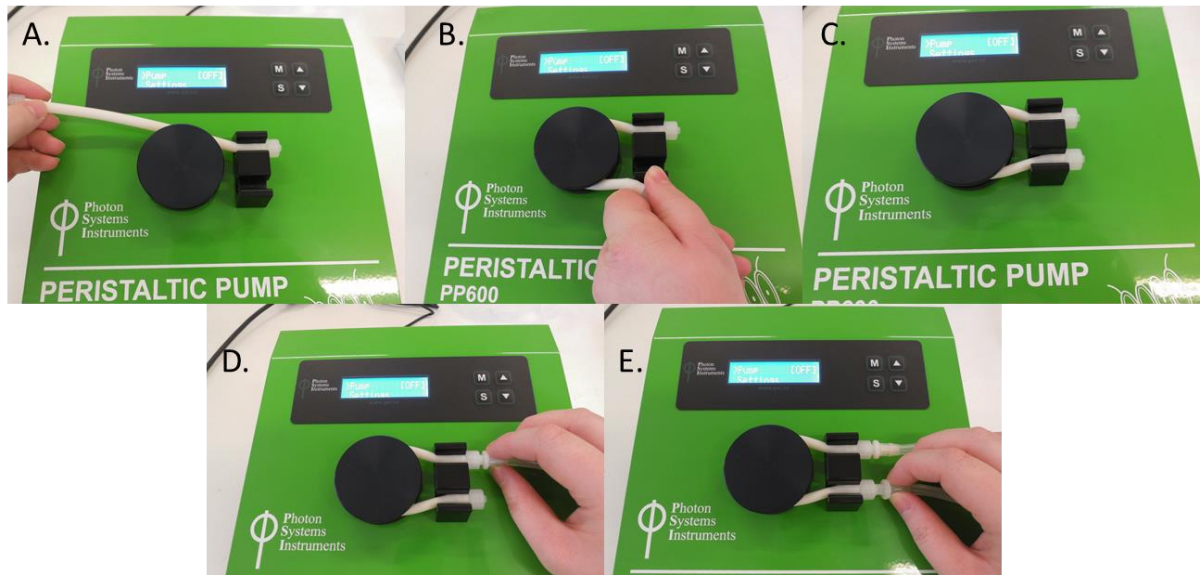

Fig. 5 Assembly of the peristaltic pump.

A, B, C) Placement of the plastic tubing (Norprene tubing 6-4mm) around the rotor. D, E) Adapter is attached to the silicone tubing and connected with the tubing of the peristaltic pump.



Fig. 6 Basic configuration of Peristaltic Pump.



Fig. 7 Power cord connection of peristaltic pump.

7. OPERATION INSTRUCTIONS

To switch the pump **ON**, press the **“MAIN”** on the rear side of the pump.

- **MANUAL CONTROL VIA THE PUMP KEYPAD (Fig. 8)**



Fig. 8 Display and keypad.

- Use the **“S”** key (below the digital display) to confirm.
- Use the **“M”** key (below the digital display) to return.
- **“UP/DOWN”** key: Use it to attain the desired value (add/subtract) or to move up/down in the menu tree (Fig. 9).

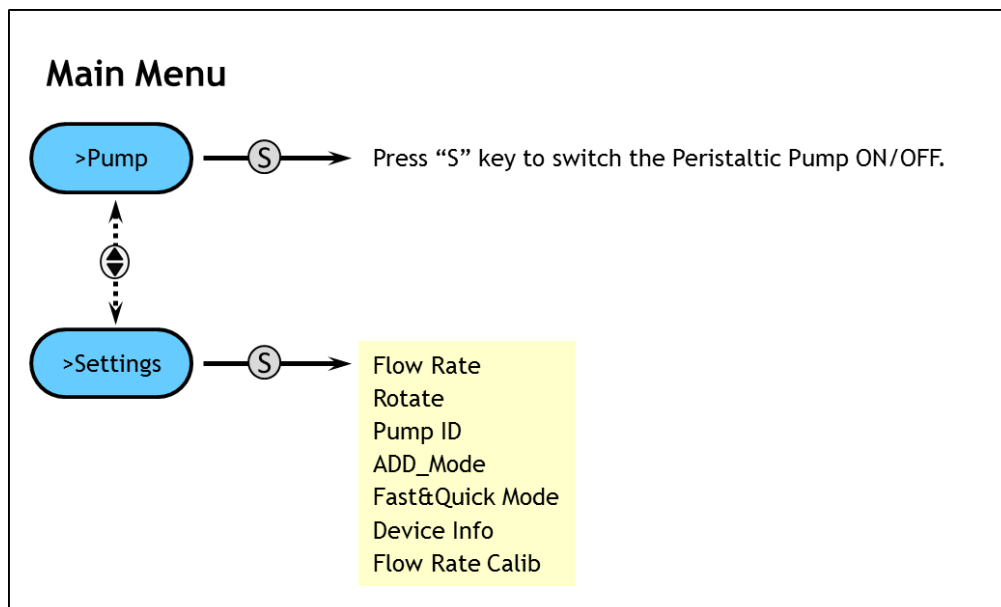

Fig. 9 Menu tree.

8. COMMAND EXPLANATION

Pump [ON/OFF]:

Press “S” key to switch the Peristaltic Pump ON/OFF.

Setting → Flow Rate:

Use this command to set the speed of rotation (flow-rate). Press “▲” key to increase the speed; press “▼” key to decrease the speed. The flow-rate range is 200 µl/min – 50,000 µl/min. For increase or decrease rotation uses short or long press:

Range	Short press	Long press
200 – 1,000 µl/min	1 µl/min	50 µl/min
1,000 – 10,000 µl/min	10 µl/min	500 µl/min
10,000 – max. value µl/min	100 µl/min	5,000 µl/min

Setting → Rotate [RIGHT/LEFT]:

Use this command to change the direction of rotor rotation. Use “S” key to set right or left rotor rotation.

Setting → Pump_ID [0 -7]:

The device construction enables cascading of up to 8 pumps sequentially in a row. Use this command to set the communication address for a particular pump used. The address of each of the pumps must be unique. Each address can serve different pump operation mode. Use “▲” and “▼” keys to set communication address numbered from 0 to 7.

Important note for connection with PBR:

The pump must be correctly identified for its proper function. Therefore, avoid connecting more Peristaltic Pumps with the same communication address to one appliance).

Setting → ADD_Mode [ON/OFF]:

→ Add Run Time: X hour, Y min, Z sec [state]

→ ADD_Period: X hour, Y min, Z sec [state]

ADD_Mode is a chemostat mode that serves for periodically repeated inflow of medium to the culture. Periodic intervals are set in the command ADD_Period. Duration of medium inflow is set in the command ADD Run Time.

Press “S” key shortly to activate / deactivate chemostat mode (ADD_Mode). Use long press “S” for switching between ADD_Period and ADD_Run Time modes. Use “▲” and “▼” keys to set desired time values.

The time range for ADD_Period is from 2 minutes to 24 hours; time steps are 1 min / 10 min (key short press / key long press). Maximum duration in ADD_Run Time mode is 10 seconds; time steps are 1 sec / 10 sec (key short press / key long press). Rotation speed corresponds to the value set in the mode Setting → Flow Rate.

If ADD_Mode is active, then the Pump Control Indicator (in the main menu) reads: Pump [C:ON/OFF]. ON/OFF status indicates whether the pump motor is switched on or switched off.

Warning:

ADD_Mode is a master mode and claims priority over the communication cable control and/or over the Pump Control Indicator (in the main menu). Therefore, if the Peristaltic Pump is to be controlled by the Photobioreactor or other external equipment, ADD_Mode must be deactivated!

Setting → Fast&Quick Mode [RIGHT/LEFT/STOP]

This mode provides a convenient way to pump the fluid at maximum possible speed without setting the flow rate.

Press “▲” key to activate the peristaltic pump rotation in the right direction. Press “▼”key to activate the peristaltic pump rotation in the left direction. Use “S” key to stop the pump rotation.

Important Note:

If the Peristaltic Pump is to be controlled by a parent device (Photobioreactor), Fast&Quick Mode must be deactivated.

Setting → Device Info

This menu provides information on:

- Firmware version number: 3.0.1.4
- Date of firmware compilation: Jan 23, 2018
- Device Type: PP600
- Build Number: 152
- Firmware ID: PP600
- Output module: [No_Module/Included] *(Refers to valve control module.)*

Setting → Flow Rate Calibration:

Is used if you want to pump exact volume of liquid in a given time, e.g, 5000 µl/60 s.

Use this command to calibrate flow rate. Press “S” key to start calibration. Calibration is running for 60 seconds, when the pump sucks the water. Then adjust the volume of liquid that flowed during the 60 s. Confirm by “S”. (Example of calibration: Take the vessel with water and put the tube of a peristaltic pump that sucks in water and at the other end of the tubing (waste) place the pre-weighed beaker. After 60 seconds reweigh beaker with water and difference set on the pump). For calibration set the basic configuration of Peristaltic Pump (Fig. 6). You can set volume from 1 – 100,000 µl/min.

Additional Notes:

The Peristaltic Pump can be controlled by the trigger signal or by commands via I2C bus and USB communication interfaces. These commands are provided to customers on demand only (*please write to: support@psi.cz*).

9. WARRANTY TERMS AND CONDITIONS

- This Limited Warranty applies only to the Peristaltic Pump PP 600. It is valid one year from the date of shipment.
- If at any time within this warranty period the instrument does not function as warranted, return it and the manufacturer will repair or replace it at no charge. The customer is responsible for shipping and insurance charges (for the full product value) to PSI. The manufacturer is responsible for shipping and insurance on return of the instrument to the customer.
- No warranty will apply to any instrument that has been (i) modified, altered, or repaired by persons unauthorized by the manufacturer; (ii) subjected to misuse, negligence, or accident; (iii) connected, installed, adjusted, or used otherwise than in accordance with the instructions supplied by the manufacturer.
- The warranty is return-to-base only, and does not include on-site repair charges such as labor, travel, or other expenses associated with the repair or installation of replacement parts at the customer's site.
- The manufacturer repairs or replaces faulty instruments as quickly as possible; the maximum time is one month.
- The manufacturer will keep spare parts or their adequate substitutes for a period of at least five years.
- Returned instruments must be packaged sufficiently so as not to assume any transit damage. If damage is caused due to insufficient packaging, the instrument will be treated as an out-of-warranty repair and charged as such.
- PSI also offers out-of-warranty repairs. These are usually returned to the customer on a cash-on-delivery basis.
- *Wear & Tear Items* (such as sealing, tubing, padding, etc.) are excluded from this warranty. The term *Wear & Tear* denotes the damage that naturally and inevitably occurs as a result of normal use or aging even when an item is used competently and with care and proper maintenance.

10. LIST OF PICTURES

FIG. 1 MODEL PP 600.	5
FIG. 2 COMPONENTS OF PERISTALTIC PUMP.	6
FIG. 3 FRONT PANEL.....	7
FIG. 4 REAR PANEL.....	7
FIG. 5 ASSEMBLY OF THE PERISTALTIC PUMP.	10
FIG. 6 BASIC CONFIGURATION OF PERISTALTIC PUMP.....	10
FIG. 7 POWER CORD CONNECTION OF PERISTALTIC PUMP.....	10
FIG. 8 DISPLAY AND KEYPAD.....	11
FIG. 9 MENU TREE.....	11

For customer support, please write to: support@psi.cz

Copyright © Photon Systems Instruments, 2019-09